

WATER TEST GAUGE

- Connects Directly to Standard Water Faucet or Hose
- Measures Commercial & Residential Water Pressure
- Dual Scale Dial

Marsh Water Test Gauge is designed to connect directly to a standard 3/4" water faucet or hose. The maxi pointer included on the Water Test Gauge allows you to monitor a peak operating or surge pressure point.

Typical applications include measuring residential and commercial water pressure, also selection and adjustment of valves, regulators, and other controls.



STANDARD RANGES & PART NUMBERS

| TYPE | WATER TEST GAUGES | |
|---------------------|---------------------------------|-------------------|
| Size | 2 1/2" | |
| Internals | Copper Alloy | |
| Case Materials | Steel | |
| Mounting/Case Style | Top mount | |
| Connection | 3/4" - 1 1/2" NH female hosebib | |
| Scale Standard | psi/kPa | |
| Window | Acrylic | Acrylic w/maxhand |
| Part Number | G24545 | G24545-001 |

SPECIFICATIONS

ACCURACY ASME
Grade B - ±3/2/3% (±2% of range across middle half of scale)

CASE SIZES
2 1/2" diameter

CASE MATERIAL
Steel, black painted

CASE STYLE
Top mount

TUBE & SOCKET
Copper alloy

MOVEMENT
Brass

CONNECTION
3/4" - 1 1/2" NH Female hosebib

RANGES
0 to 300 psi

DIAL STANDARD
Dual scale psi and kPa

DIAL COLOR
Black markings on white

POINTER
Aluminum, black painted

WINDOW
Acrylic with or without red maximum indicating pointer

OPTIONS
Other ranges are available
Consult factory





PAPER MACHINE GAUGE

- Hinged Ring Chrome Plated Steel Case
- Protective Weather Tight Seal
- Restrictor is Standard

Marsh Instruments Chrome Plated Paper Machine Gauges are available in nine ranges and fit existing panel cutouts. The heavy-duty case features a front flanged/ hinged ring design which allows easy access to the recalibrator and a weep hole that prevents condensation buildup. A restrictor is standard. The Marsh Paper Machine Gauge is available in 3 1/2" size only. Each gauge has a weather-tight seal to protect against dust and atmospheric contaminants. Marsh Instruments Paper Machine gauges are specifically designed to meet the demands of the pulp and paper industry.

SPECIFICATIONS

ACCURACY

ASME Grade A - $\pm 2/1/2\%$ ($\pm 1\%$ of range across middle half of scale)

CASE SIZES

3 1/2" diameter

CASE MATERIAL

Steel, chrome plated

CASE STYLE

LBM - Lower Back Mount

TUBE & SOCKET

Copper alloy

MOVEMENT

Stainless Steel with recalibrator

CONNECTION

1/4 NPT

RANGES

30 to 1,000 psi

DIAL STANDARD

Single scale psi

DIAL COLOR

Black markings on white

POINTER

Aluminum, black painted

WINDOW

Glass lens, chrome plated brass ring with weather-tight seal

RESTRICTOR

Standard

STANDARD RANGES & PART NUMBERS

| TYPE | PAPER MACHINE GAUGES |
|-----------------------|----------------------|
| Size | 3 1/2" |
| Case Material | Steel, Chrome Plated |
| Internals | Copper Alloy |
| Mounting / Case Style | LBM |
| Connection | 1/4 NPT |
| Scale Standard | psi |
| 0 to 30 psi | W6042 |
| 0 to 60 psi | W6046 |
| 0 to 100 psi | W6048 |
| 0 to 160 psi | W6052 |
| 0 to 200 psi | W6054 |
| 0 to 300 psi | W6058 |
| 0 to 400 psi | W6060 |
| 0 to 600 psi | W6064 |
| 0 to 1,000 psi | W6072 |

PAPER MACHINE GAUGE OPTIONS

| OPTION | TYPE | SUFFIX | AVAILABLE ON MODELS |
|---------------|--------------------------|--------|---|
| Restrictor | Special Restrictor | H | |
| | No restrictor | H1 | |
| Catalog Dials | bar only | L1 | See Marsh Price List for minimum |
| | kg/cm ² only | L2 | |
| | kPa only | L3 | |
| | MPa only | L4 | |
| | psi & bar | W1 | |
| | psi & kg/cm ² | W2 | |
| | psi & kPa | W3 | |
| | psi & MPa | W4 | |
| Custom Dials | Logo or custom face | M | Consult factory for colors and minimums |

PAPER MACHINE GAUGE DIMENSIONS

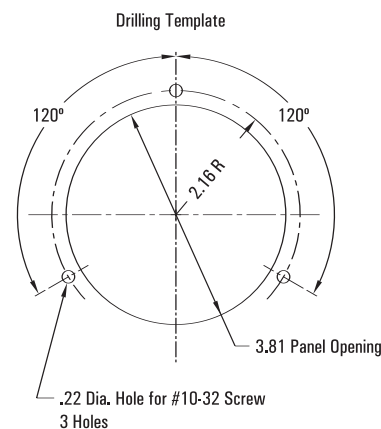
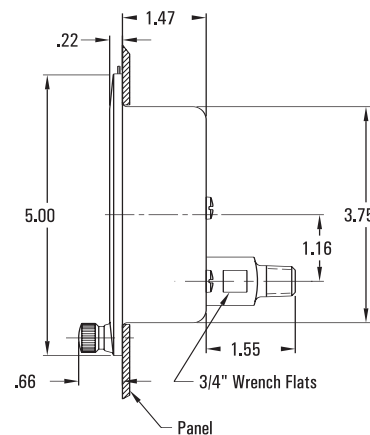

X-MAS TREE GAUGE

- Accuracy $\pm 1\%$
- Polished Stainless Steel Case
- Ranges to 10,000 psi
- Adjustable Micrometer Pointer

Marsh Instruments has been on top of X-mas Trees and well-heads longer than any other name. Marsh offers the same high-performance gauge for replacement. Other gauge manufacturers can state X-mas Tree Gauge on their products but only Marsh Instruments can offer you all the special features, and dependability, that you expect! Features include a polished stainless steel case with stainless steel tube, tip, and socket, and an easy to adjust micrometer pointer.

Marsh Instruments X-mas Tree gauges are designed for the oil patch, well heads and offshore oil platforms.



STANDARD RANGES & PART NUMBERS

| TYPE | X-MAS TREE GAUGE |
|-----------------------|---------------------|
| Size | 4½" |
| Case Material | 304 Stainless Steel |
| Internals | Stainless Steel |
| Mounting / Case Style | LM |
| Connection | ½ NPT |
| Scale Standard | psi |
| 0 to 1,000 psi | W0574 |
| 0 to 1,500 psi | W0578 |
| 0 to 2,000 psi | W0582 |
| 0 to 3,000 psi | W0586 |
| 0 to 5,000 psi | W0590 |
| 0 to 10,000 psi | W0594 |

SPECIFICATIONS

ACCURACY

ASME Grade A – $\pm 1\%$
($\pm 1\%$ of range across full scale)

CASE SIZES

4½" diameter

CASE MATERIAL

304 Stainless Steel

CASE STYLE

LBM – Lower Mount
with blowout plug

TUBE & SOCKET

Stainless Steel

MOVEMENT

316 Stainless Steel

CONNECTION

½ NPT

RANGES

1,000 to 10,000 psi

DIAL STANDARD

Single scale psi

DIAL COLOR

Black markings on white

POINTER

Aluminum, black painted,
micro-adjustable.

WINDOW & RING

Acrylic window with bayonet ring

